

NEW DRAWING TOOLS FROM PRAMET

- **TOP QUALITY** drawing rings and dies for very accurate tubes and rods
- **ADVANCED TECHNOLOGY** for inside grinding with high accuracy of form
- **WIDE RANGE** of cemented carbide grades for most types of drawing operations

Important features and product dimensions:

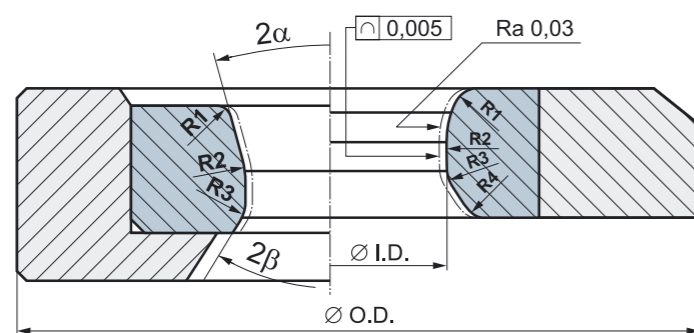

- Inside diameter max 100 mm \pm 0,0025
- Outside diameter max 220 mm
- Weight of workpiece max 15 kg
- Contour form accuracy \varnothing 0,005 mm
- Contour surface quality R_a 0,03
- Tangential intersection accuracy 0,001 mm

HEAD OFFICE :



Pramet Tools, s.r.o., Uničovská 2, CZ - 787 53 Šumperk
 Tel.: + 420 / 583 381 111, Fax: + 420 / 583 381 548, E-mail: pramet.info.cz@pramet.com, www.pramet.com

SUBSIDIARIES:



Pramet Slovakia, spol. s r.o., Dolné Rudiny 1, SK - 010 81 Žilina
 Tel.: + 421 41 / 764 54 60, Fax: + 421 41 / 763 74 49, E-mail: pramet.info.sk@pramet.com, www.pramet.sk



Pramet GmbH, Am Weichselgarten 34, D - 91058 Erlangen
 Tel.: + 49 9131 / 93 37 40, Fax: + 49 9131 / 93 37 42, E-mail: pramet.info.de@pramet.com, www.pramet.de



Pramet Sp. z o.o., ul. Słowackiego 16, PL - 40-084 Katowice
 Tel.: + 48 32 / 78 15 890, Fax: + 48 32 / 25 87 593, E-mail: pramet.info.pl@pramet.com, www.pramet.pl



Pramet SRL, Via Re Umberto I, 33, I - 20020 Lainate (MI)
 Tel.: + 39 02 / 93 79 94 82, Fax: + 39 02 / 93 73 102, E-mail: pramet.info.it@pramet.com, www.pramet.it



NEWS



PRECISE DRAWING TOOLS

open contours